

Masport®

REEL LAWN MOWER

OPC 400 Series

<u>Mower</u>	<u>Model</u>	<u>Engine</u>	<u>Shaft Dia</u>	<u>Introduction</u>	<u>Serial Number</u>
019026	400 PRR	B&S 3.5 I/C	19	Dec 2007	7091925
019036	400 RRR	B&S 3.5 I/C	19	Jun 2010	7318620
019043	400 PRR	Honda GX160	20	May 2010	7311104
019044	400 RRR	Honda GX160	20	Mar 2009	7199092
019057	400 PRR	Honda GC160	20	April 2011	7421017
019058	400 RRR	Honda GC160	20	Aug 2010	7333156
019066	400 RRR	Kawasaki FJ100D	20	Aug 2010	-----
019090	400 PRR	B&S 3.5 I/C	19	Jan 2011	7412506

PRR = Reel Mowers fitted with a Painted Rear Roller

RRR = Reel Mowers fitted with a Rubber Sleeve over the Painted Rear Roller

Uprturned Style Handle Used On:
019090



Issue B.1
ECN 02926
Jan 2015 PB
REF # 719057S



400 Series
Reel Mower

Masport

Issue B.1
Jan 2015 PB
REF # 719057S

NOT ILLUSTRATED

031887	Decal, Caution S/N & dB 400	1
031890	Decal, Trans Cvr 400	1
031893	Decal, G/Catcher 400	1
031900	Decal, Caution, Feet & Hands	1
031992	Owner Manual, Reel Mower	1
569323	Warranty Card MASP	1
571100	Decal, Power Drive	1
Honda Engine's require		
503630	Screw,S/T 10x.4	2
503950	Deflector-Honda Engine	1
Honda - Throttle Cable Routing Change TB129		
503489	Screw, Set M5 x 16	1
550555	Clamp- Cable, Throttle Adapter	1

731581 Catcher Assy, 400 Green 1



OPC Safety Cut Out Assy

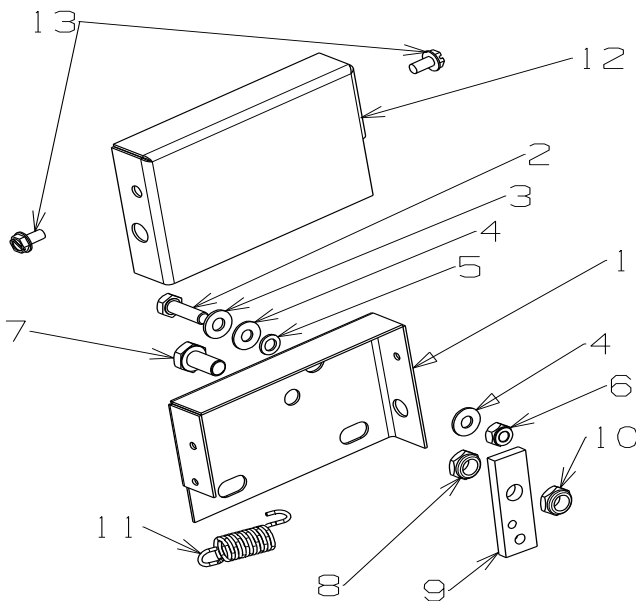

Item No	Part No	Description	Qty
1	031880	Safety Switch Housing	1
2	501600	Screw,Set M6x16 Hex	1
3	501703	Washer,Fit M6x14x1.2	1
4	031884	Washer,Fibre M6x14x1	2
5	031883	Washer,Fibre M6x10x1	1
6	501764	Nut,M6 Nyloc x 6mm Thick	1
7	501597	Screw,Set M8x20 Hex	1
8	503831	Nut,M8 Nyloc x 6mm Thick	1
9	031885	Safety Switch Lever Arm	1
10	503831	Nut,M8 Nyloc x 6mm Thick	1
11	031886	Spring	1
12	031881	Safety Switch Cover	1
13	580540	Screw,S/T M5x10 POZ	2

NOT ILLUSTRATED

031906	Safety Switch Loom B&S	1
(Fit spade onto item 2 prior to assembly)		
031882	Safety Switch Loom Honda	1
(Fit spade onto item 2 prior to assembly)		



Chassis Assembly

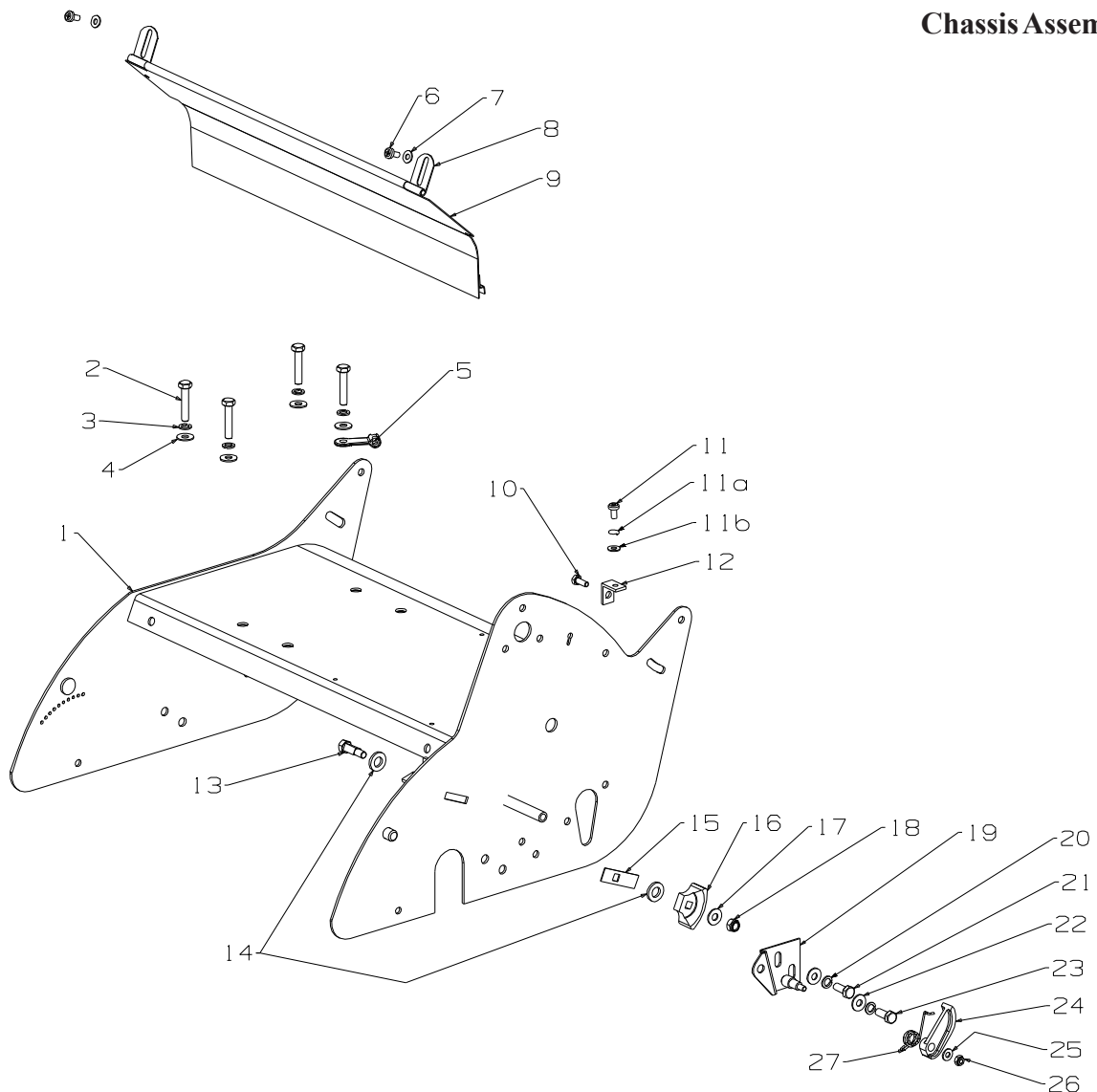

Item No	Part No	Description	Qty	Item No	Part No	Description	Qty
1	031580	Chassis Assy- 400 Green	1	14	006028	Washer, Flt 12x22x3.0	2
2	501843	Set Screw, M8x40 Hex	4	15	002845	Sealplate- Chain Adjuster	1
3	503747	Washer, Spg 8	4	16	002844	Adjuster- Chain, Fixed Nylon	1
4	501606	Washer, Flt 8x19x1.6	4	17	501606	Washer, Flt 8x19x1.6	1
5	581527	Retainer, Clutch Cable	1	18	501793	Nut, M8 Hex Nyloc 8 Thck	1
6	503591	Screw, Pan M6x12	2	19	004942	Plate Assy, Mounting	1
7	501703	Washer, Flt 6x14x1.2	2	20	503747	Washer Spg 8	2
8	002589	Bracket, Grass Chute	2	21	501571	Set Screw, M 8X 16 Hex	1
9	008900	Deflector, Grass- 400	1	22	501606	Washer, Flt 8x19x1.6	2
10	501702	Set Screw, M6x16 Hex	1	23	501571	Set Screw, M8x16 Hex	1
11	503591	Screw, Pan M6x12	1	24	004963	Adjuster- Chain, Tension Nylon	1
11a	500201	Washer, Spg 6	1	25	501703	Washer, Flt 6x14x1.2	1
11b	501703	Washer, Flt 6x14x1.2	1	26	501764	Nut, M6 Hex Nyloc 6 Thck	1
12	031915	Bracket- Chain Cover	1	27	004945	Spring	1
13	002848	Bolt- Adjuster, Chain	1				



Cutting Cylinder Assembly

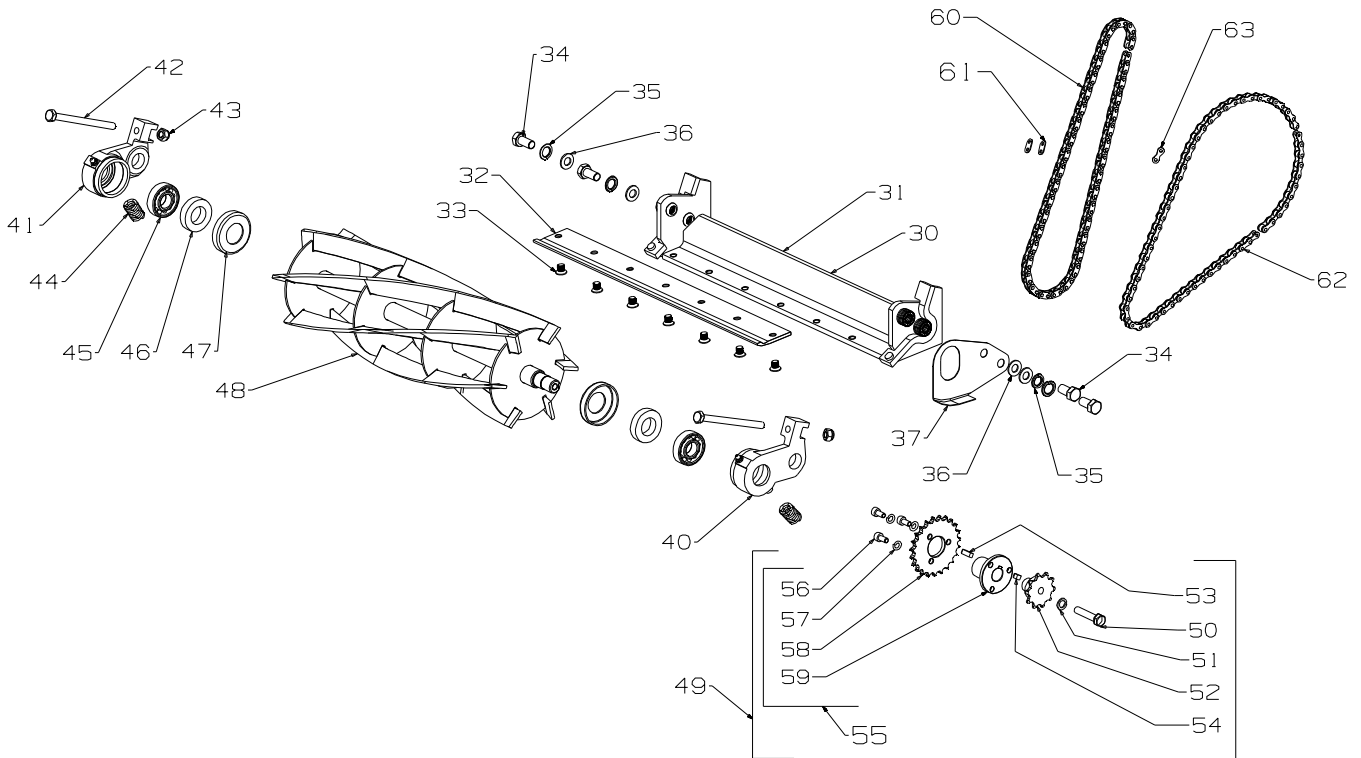

Item No	Part No	Description	Qty	Item No	Part No	Description	Qty
30	009853	Backplate Brkt, Blade Assy 400	1	49	032006	Sprocket Assy-10/23	1
		(incl items,31,32,33)		50	*501843	Set Screw, M8 x 40	1
31	*009861	Bracket Assy Backplate 400	1	51	*503747	Washer Spg 8	1
32	*009872	Blade, Baseplate 400	1	52	*032002	Sproket 10T	1
33	*008611	Screw, CSK M8x10 Allen Head	7	53	*032005	Key 5x5x16	1
		__==__		54	*032004	Key 5x5x10	1
34	501760	Set Screw, M10x20 Hex	4	55	*032045	Sprocket Assy - 23 Key	1
35	503897	Washer, Spg 10	4			(incl items 56,57,58 and 59)	
36	501704	Washer, Flt 10x19x1.6	4	56	*502004	Screw,Cap M6x12	3
37	002561	Plate- Seal, Chaincase	1	57	*500201	Washer, Spg 6	3
40	032023	Housing- Assy Bearing, LH	1	58	*032003	Sprocket 23T	1
41	032024	Housing- Assy Bearing, RH	1	59	*032001	Boss Sprocket Key	1
42	006282	Bolt, Set NF 5/16"x4" Hex	2	60	002835	Chain- 0.23xP 3/8", 75P	1
43	007240	Nut, NF 5/16 Hex Nyloc Type "P"	2	61	*731972	Link- Chain 3/8"	1
44	002581	Spring-Baseplate	2	62	004299	Chain- 0.205x P 1/2", 59P	1
45	503273	Bearing, Ball 17x40x12 6203 2S	2	63	*731971	Link- Chain 1/2"	1
46	002583	Seal-Felt	2				
47	005211	Cover- Dust, Cylinder Bearing	2				
48	032013	Cylinder Assy Cutting-400, Keyed	1				



70 Front Roller Assembly

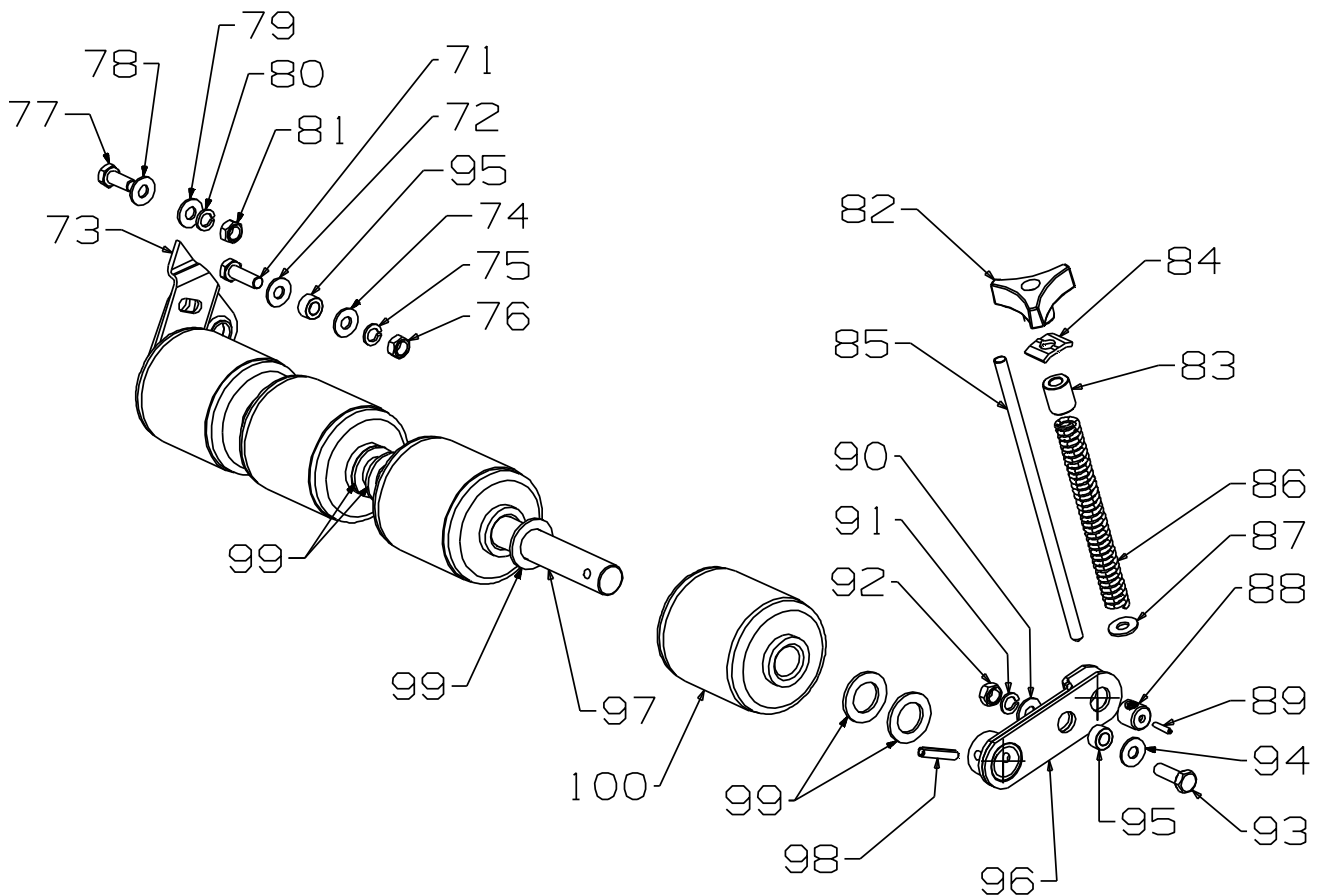

Item No	Part No	Description	Qty	Item No	Part No	Description	Qty
70	005013	Spindle & Brkt Assy 400	1	87	*501606	Washer, Flt 8x19x1.6	1
71	*501598	Set Screw, M8x25 Hex	1	88	*004990	Spindle, Trunnion	1
72	*501606	Washer, Flt 8 x 19 x 1.6	1	89	*032087	Pin, Tension 3.0 x 16	1
73	*004983	Bracket- Front Roller, RH	1	90	*501606	Washer, Flt 8x19x1.6	1
74	*501606	Washer, Flt 8x19x1.6	1	91	*503747	Washer, Spg 8	1
75	*503747	Washer, Spg 8	1	92	*501602	Nut, M8 Hex	1
76	*501602	Nut, M8 Hex	1	93	*501598	Set Screw, M8x25 Hex	1
77	*501597	Set Screw, M8x20 Hex	1	94	*501606	Washer, Flt 8x19x1.6	1
78	*501606	Washer, Flt 8x19x1.6	1	95	*004991	Bush- Pivot, Front Roller	2
79	*501606	Washer, Flt 8x19x1.6	1	96	*004984	Bracket Assy- Adj, Front Roller	1
80	*503747	Washer, Spg 8	1	97	*004976	Spindle Assy Front 400	1
81	*501602	Nut, M8 Hex	1	98	*007496	Pin, Tension 6.0 x 30	1
82	*574230	Knob- Plastic, M8 Insert	1	99	*501432	Washer, Flt 20x33x4.0	8
83	*031910	Spacer- Knob	1	100	031911	Roller-Front Assy (1 Only)	4
84	*004973	Plate Slipper	1		*005476	Shell-Front Roller	1
85	*004988	Spindle- Adj, Front Roller	1		*005478	Cap-End	2
86	*004691	Spring- Height Adjust	1				



400 Series
Reel Mower

Masport

Issue B.1
Jan 2015 PB
REF # 719057S

MSV Handle Assembly

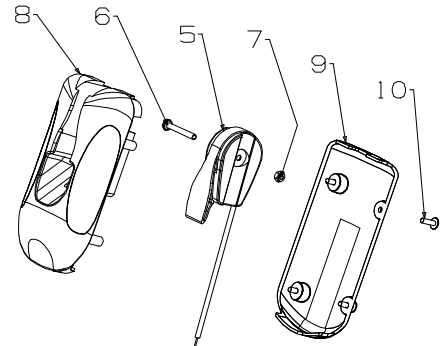
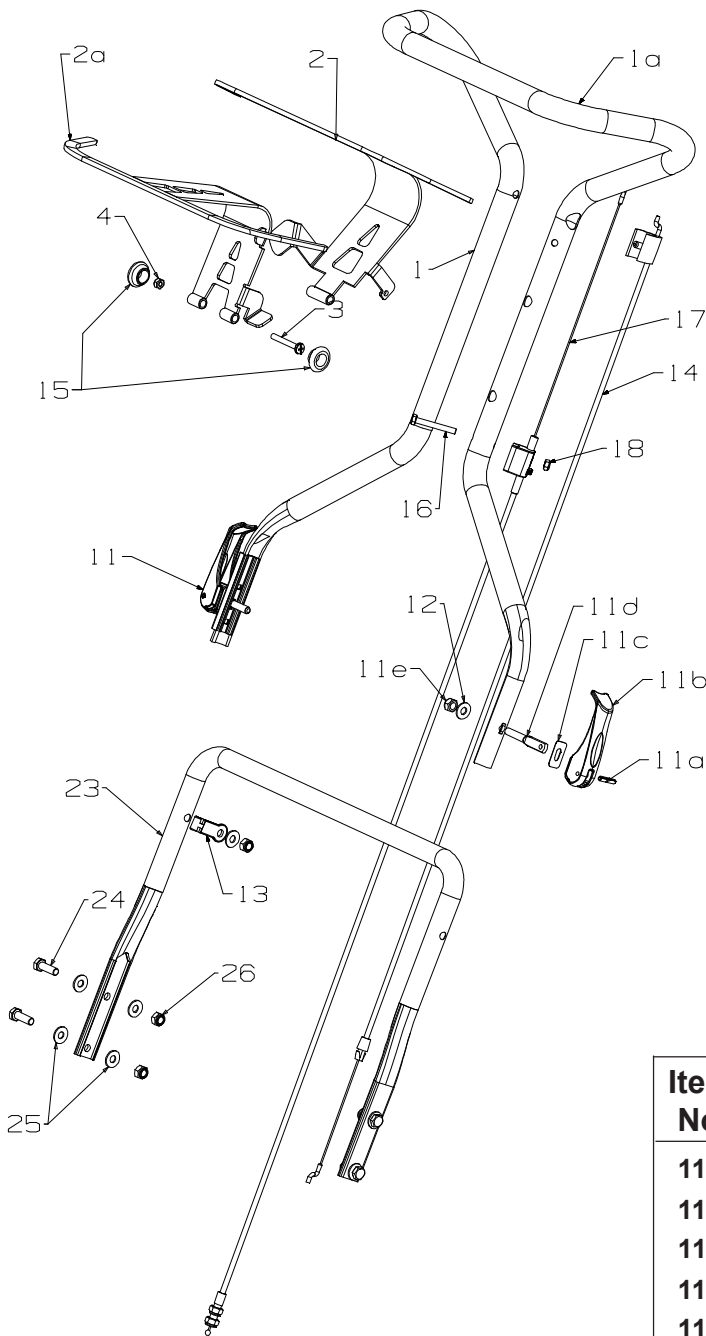

Item No	Part No	Description	Qty
1/1a	731847	Handle & Sleeve Assy	1
2	579279	Bail Arm Assy, SP MSV	1
2a	979278	Bail Arm Assy, OPC MSV	1
3	503883	Bolt Hex M8 x 100	1
4	501793	Nut-M8 Nyloc	1
5	583458	Control- Throttle,Hsng Wscn	1
6	503604	*Screw, Pan M6x45	1
7	501764	*Nut, M6 Nylocx 6 Thck	1
8	983351	Mount Throttle, Top Plain	1
9	583340	Cover Throttle Bottom	1
10	503650	Screw; S/T #12x11/16"	4

Item No	Part No	Description	Qty
11	779755	Cam Lock Assy- MSV	2
11a	503369	*Pin, Tension 5.0 x25	1
11b	582419	*Lever Handle Locking	1
11c	016777	*Washer Slipper	1
11d	583041	*Stud Handle Lock 61mm	1
11e	501793	*Nut M8 Hex Nylocx Thck	1
12	501606	Washer, Flat 8x19x1.6	2
13	581527	Retainer, Clutch Cable	1
14	581655	Cable-Engine,OPC	1
15	503882	Grommet Blanking 3/4"(19mm)	2
16	503558	Screw-Set, M6 x 45	1
17	031990	Cable-Clutch, Reel Mower	1
18	501764	Nut-M6 Nyloc	1
23	031848	Handle- Lower, 400	1
24	501597	Screw, Set M8x20	4
25	501606	Washer, Flat 8x19x1.6	8
26	501793	Nut, M8 Nylocx 8 Thck	4

When ordering PLEASE QUOTE PART NUMBER & Description, NOT Illustration No.
Determine right or left hand side from standing in operating position (standing at handle)
Bold Text = Assemblies, Bulleted Text * = Items included in the Assemblies



Upturned Handle Assembly Used on 019090

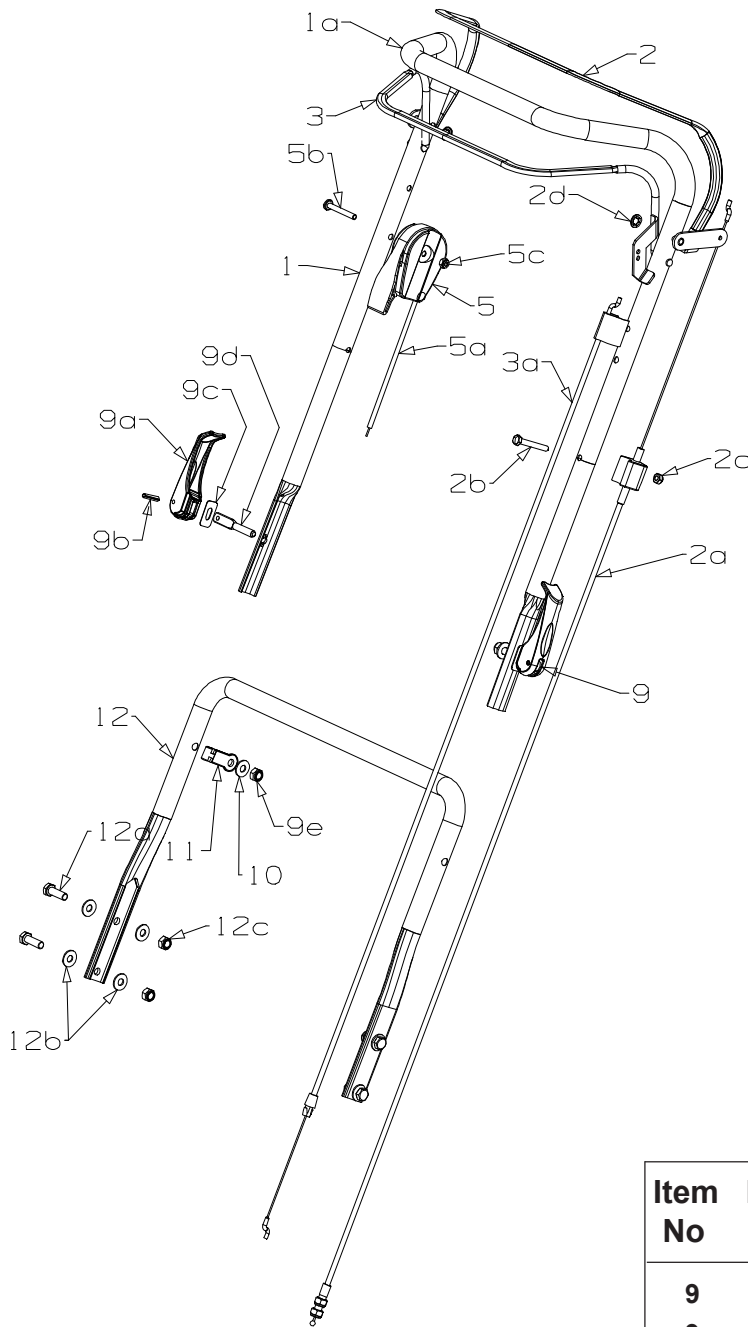

Item No	Part No	Description	Qty
1/1a	773155	Handle- Upper,Upt OPC	1
2	982161	Bail Arm Assy, SP	1
2a	031990	Cable-Clutch, Reel Mower	1
2b	503558	Screw-Set, M6 x 45	1
2c	501764	Nut-M6 Nyloc	1
2d	501365	Clip- Starlock, 5/16"	2
3	981740	Bail Arm Assy, OPC	1
3a	031878	Cable- Eng, OPC Reel Mower	1
5/5a	583458	Control- Throttle,Hsng Wscn	1
5b	503604	*Screw, Pan M6x45	1
5c	501764	*Nut, M6 Nylocx 6 Thck	1

Item No	Part No	Description	Qty
9	779755	Cam Lock Assy- MSV	2
9a	582419	*Lever- Handle, Locking	1
9b	503369	*Pin, Tension 5.0 x25	1
9c	016777	*Washer Slipper	1
9d	583041	*Stud Handle Lock 61mm	1
9e	501793	*Nut M8 Hex Nylocx Thck	1
10	501606	Washer, Flat 8x19x1.6	2
11	581527	Retainer- Clutch Cable	1
12	031848	Handle- Lower, 400	1
12a	501597	Screw, Set M8x20	4
12b	501606	Washer, Flat 8x19x1.6	8
12c	501793	Nut, M8 Nylocx 8 Thick	4



Clutch Assembly

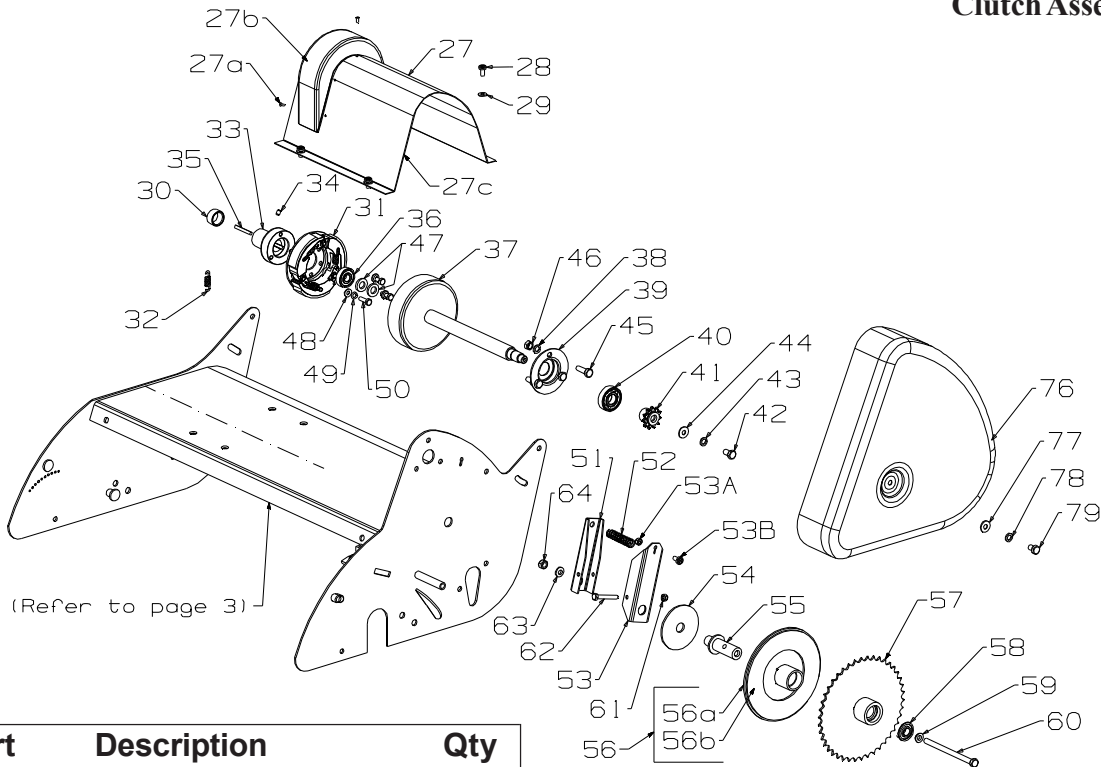

Item No	Part No	Description	Qty	Item No	Part No	Description	Qty
27	031908	Cover- Trans, 400 GRN	1	50	503223	Screw, Set M6x16 HT8.8	3
27a	503429	*Rivet Pop 3.2 x4.8 73 AS4-3	4	51	031831	Lever- Clutch	1
27b	031907	*Cover Trans Moulded	1	52	031845	Spring- Clutch	1
28	503591	Screw, Set M6x12	4	53	031830	Lever Carrier- Clutch	1
29	501703	Washer, Flt 6x14x1.2	4	53a	501764	Nut-M6 Nyloc	1
30	031958	Spacer- Drive Shaft, 13mm	1	53b	503591	Screw-Pan M6 x 12	1
31	031912	Clutch- Drive Assy	1	54	031843	Washer. FLT 16.5x75x3.0	1
32	005634	*Clutch Spring	3	55	031840	Post- Clutch	1
33	031913	Boss- Clutch, 19 Dia (536012 Key)	1	56	031988	Sprocket-11T, Clutch Disk	1
33	031914	Boss- Clutch, 20 Dia (536178 Key)	1	56a	031986	*Sprocket- Clutch Plate Assy	1
34	501719	Screw, Grb M6x8	2	56b	031987	*Liner- Clutch Face Cork	1
35	536178	Key- Engine 3/16"SQx24	1	57	031963	Sprocket- 42T, Plate & Boss Assy	1
35	536012	Key- Engine 3/16"SQx38	1	58	503901	Bearing, Ball 12x28x8 6001 2RSH	1
36	501213	Bearing, Ball 12x32x10 6201 2RS	1	59	031965	Washer- Centralizing Brass	1
37	031579	Drum Assy, Clutch 400	1	60	503938	Bolt, M8x120 Hex	1
38	503747	Washer, Spg 8	3	61	501764	Nut, M6 Nyloc 6 Thck	1
39	002834	Housing- Bearing	1	62	580160	Screw, Set M6x50 Hex	1
40	503273	Bearing-Ball 17x40x12 6203 2S	1	63	031842	Washer, Thrust	1
41	002818	Sprocket- 11T, Drive	1	64	501793	Nut, M8 Hex Nyloc 8 Thck	1
42	501715	Screw, Set M8x15 1mm Pitch	1	76	031585	Cover - Chaincase- Green	1
43	503747	Washer, Spg 8	1	77	501606	Washer, Flt 8x19x1.6	1
44	501606	Washer, Flt 8x18x1.6	1	78	503747	Washer, Spg 8	1
45	501597	Screw, Set M8x20 Hex	3	79	501863	Screw Set, M8x12	1
46	501602	Nut, M8 Hex	3				
47	006028	Washer, Flt 12x22x3.0	2				
48	501703	Washer, Flt 6x14x1.2	3				
49	500201	Washer, Spg 6	3				



400 Series
Reel Mower

Masport

Issue B.1
Jan 2015 PB
REF # 719057S

Reel Mower
019026
019043
019057
019090

93 Rear Roller Assembly Painted

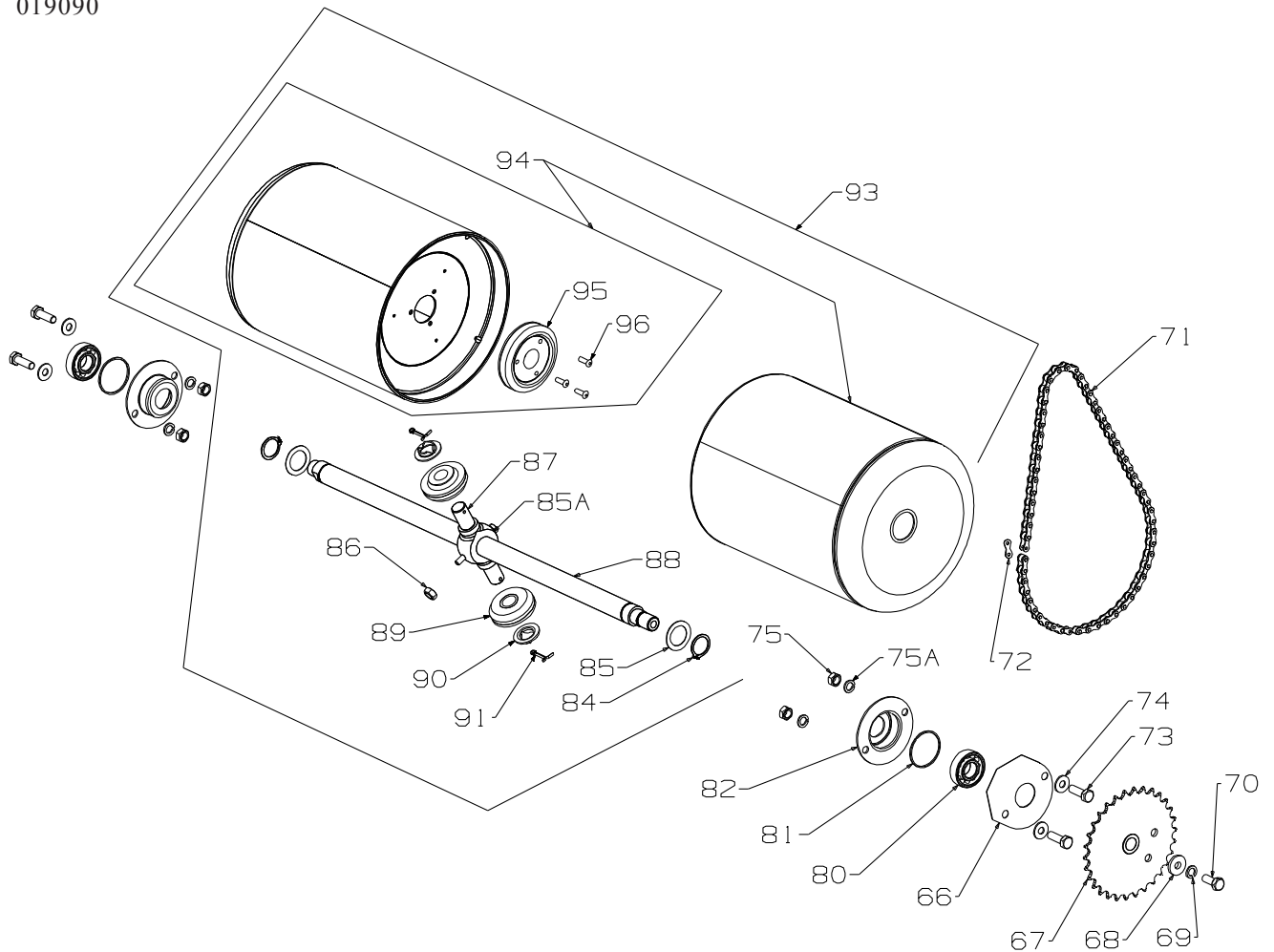

Item No	Part No	Description	Qty	Item No	Part No	Description	Qty
66	002618	Plate- Seal, Bearing	1	84	*007260	Circlip- 7/8" ext	2
67	002604	Sprocket & Boss Assy, Rear Roller	1	85	*002732	Washer-Flt, 22 x 40 x 2	2
68	503872	Washer, Flt 8x20x3.0	1	85a	*567292	Bolt-Hex M6 x 55 HT 8.8	1
69	503747	Washer, Spg 8	1	86	*501764	Nut, M6 Hex Nyloc	1
70	501717	Screw, Set M8x20 1mm Pitch	1	87	*008943	Carrier-Bevel Pinion	1
71	004929	Chain, 3/16" x 1/2, 40P	1	88	*008945	Spindle-Rear Roller Assy, 400	1
72	*731971	Link, Chain 1/2	1	89	*002708	Pinion-Bevel, 14T	2
73	501597	Screw, Set M8x20	4	90	*008944	Collar	2
74	501606	Washer, Flt 8x19x1.6	4	91	*007473	Split Pin, 3.0dia x 30	2
75	501602	Nut, M8 Hex	4	93	*031916	Roller-Rear, Assembly (Painted)	1
75a	503747	Washer, Spg 8	4	94	031954	Roller-Rear, Half 400 (Painted)	2
80	503273	Bearing-Ball 17x40x12 6203 2S	2	95	*002707	Gear-Bevel, 24t	1
81	004292	Ring-Bearing Housing	2	96	*503399	Rivet-Pop, 4.8 x 13 73 SS 6-8	3
82	000409	Housing-Bearing	2				

When ordering PLEASE QUOTE PART NUMBER & Description, NOT Illustration No.
Determine right or left hand side from standing in operating position (standing at handle)
Bold Text = Assemblies, Bulleted Text * = Items included in the Assemblies



400 Series
Reel Mower

Masport

Issue B.1
Jan 2015 PB
REF # 719057S

Reel Mower
019036
019044
019058
019066

92 Rear Roller Assembly Sleeved

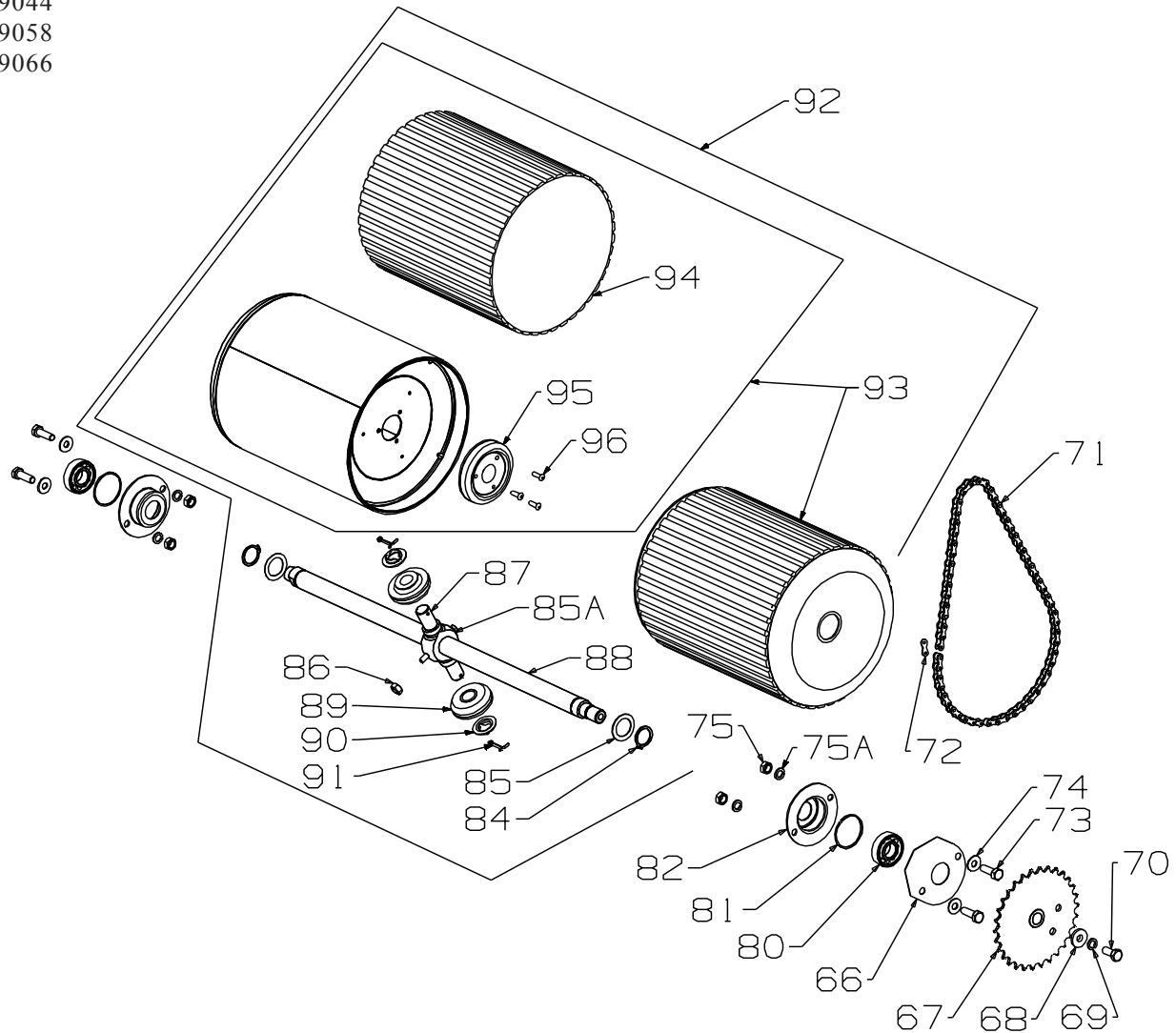

Item No	Part No	Description	Qty	Item No	Part No	Description	Qty
66	002618	Plate- Seal, Bearing	1	84	*007260	Circlip- 7/8" ext	2
67	002604	Sprocket & Boss Assy, Rear Roller	1	85	*002732	Washer-Fit, 22 x 40 x 2	2
68	503872	Washer, Flt 8x20x3.0	1	85a	*567292	Bolt-Hex M6 x 55 HT 8.8	1
69	503747	Washer, Spg 8	1	86	*501764	Nut, M6 Hex Nyloc	1
70	501717	Screw, Set M8x20 1mm Pitch	1	87	*008943	Carrier-Bevel Pinion	1
71	004929	Chain, 3/16" x 1/2, 40P	1	88	*008945	Spindle-Rear Roller Assy 400	1
72	*731971	Link, Chain 1/2	1	89	*002708	Pinion-Bevel, 14T	2
73	501597	Screw, Set M8x20	4	90	*008944	Collar	2
74	501606	Washer, Flt 8x19x1.6	4	91	*007473	Split Pin, 3.0dia x 30	2
75	501602	Nut, M8 Hex	4	92	008953	Roller-Rear,Assy 400 (Sleeved)	1
75a	503747	Washer, Spg 8	4	93	*031951	Roller-Rear,Half 400 (Sleeved)	2
80	503273	Bearing-Ball 17x40x12 6203 2S	2	94	*004618	Sleeve-Rubber,Rear Roller 400	1
81	004292	Ring-Bearing Housing	2	95	*002707	Gear-Bevel, 24t	1
82	000409	Housing-Bearing	2	96	*503399	Rivet-Pop, 4.8 x 13 73 SS 6-8	3

When ordering PLEASE QUOTE PART NUMBER & Description, NOT Illustration No.
Determine right or left hand side from standing in operating position (standing at handle)
Bold Text = Assemblies, Bulleted Text * = Items included in the Assemblies